



PROFESSIONAL COLLECTION

SURFACE MOUNT SPEAKERS



PS50B | PS50W



PS60B | PS60W



PS80B | PS80W

INSTALLATION MANUAL



Table of Contents

1. Introduction	1
2. Certifications & Safety Agency Compliance	1
3. Specifications	2
4. What's Included	3
5. Product Features	3
6. 70V/100V System	5
7. Speaker Wire	6
8. Wire Routing	7
9. Wiring Diagram	8
10. Speaker Placement	8
11. Installation	9
12. Pivoting The Speaker	14
13. Safety Agency Compliance	14
14. Troubleshooting	18
15. Technical Assistance	19
16. Limited 5-Year Warranty	19
17. Return Process	20



1. Introduction

Thank you for purchasing the Professional Collection Surface Mount Speaker. All of Origin Acoustics' speakers are designed to have excellent sound quality, longevity, and a simple installation process.

This instruction booklet covers the necessary information for a smooth installation, including: the tools you will need, step-by-step instructions for installation, troubleshooting tips for any errors that may occur, and all warranty information. If for any reason you experience problems or if you have installation questions please call us at (844) 674-4461. Hours of operation are 8:00am to 5:00pm (Pacific Time), Monday through Friday.

2. Certifications

SAFETY AGENCY COMPLIANCE

Origin Acoustics Professional Collection Surface Mount Speaker models PS80B/ PS80W, PS60B/ PS60W, PS50B/ PS50W meet the following standards:

UL 1480A: Standard for Speakers for Commercial and Professional Use

IEC 60529: IPX4 Rated



*All product information is subject to change. Please refer to www.originacoustics.com for the latest information.

3. Specifications

PS80B | PS80W

Part: SSP80000B, SSP80000W

Woofers: 8" IMPP

Tweeter: 1" Aluminum

Power Handling (Program Power): 120 W

Power Handling (Continuous Pink Noise): 60 W

Frequency Response (- 10dB): 42Hz-20kHz

Frequency Response (- 3dB): 58Hz-20kHz

Nominal Coverage Angle: 70° Horizontal,
70° Vertical

Sensitivity @1m: 92dB

Rated Maximum SPL: 107dB

Impedance : 8 Ω / 70V

Transformer Taps: 70V: 80W, 40W, 20W, 10W

100V: 80W, 40W, 20W

Dimensions: 9 1/2" W x 9 3/16" D x 14" H

(241 W x 233 D x 355 H mm)

15" (381 mm) H with bracket

PS60B | PS60W

Part: SSP60000B, SSP60000W

Woofers: 6 1/2" IMPP

Tweeter: 1" Aluminum

Power Handling (Program Power): 80 W

Power Handling (Continuous Pink Noise): 40 W

Frequency Response (- 10dB): 45Hz-20kHz

Frequency Response (- 3dB): 65Hz-20kHz

Nominal Coverage Angle: 100° Horizontal,
50° Vertical

Sensitivity @1m: 92dB

Rated Maximum SPL: 106dB

Impedance: 8 Ω / 70V

Transformer Taps: 70V: 60W, 30W, 15W, 7.5W

100V: 60W, 30W, 15W

Dimensions: 7 7/8" W x 8" D x 12 1/4" H

(200 W x 203 D x 311 H mm)

13 1/4" (336 mm) H with bracket

PS50B | PS50W

Part: SSP50000B, SSP50000W

Woofers: 5 1/4" IMPP

Tweeter: 1" Aluminum

Power Handling (Program Power): 60 W

Power Handling (Continuous Pink Noise): 30 W

Frequency Response (- 10dB): 55Hz-20kHz

Frequency Response (- 3dB): 74Hz-20kHz

Nominal Coverage Angle: 100° Horizontal,
50° Vertical

Sensitivity @1m: 89dB

Rated Maximum SPL: 105dB

Impedance: 8 Ω / 70V

Transformer Taps: 70V: 30W, 15W, 7.5W, 3.8W

100V: 30W, 15W, 7.5W

Dimensions: 6 3/4" W x 7" D x 10" H

(171 W x 178 D x 254 H mm)

11" (279 mm) H with bracket

*All product information is subject to change. Please refer to www.originacoustics.com for the latest information.

4. What's Included

Speaker

- A • Wall Bracket Mounting Hole Template
- B • 6 x Screws (1 $\frac{5}{8}$ " length)
- C • Eyelet Hook
- D • Grille Removal Key
- E • Grille Adhesives
- F • Powder Coated Aluminum Grille [Black or White]

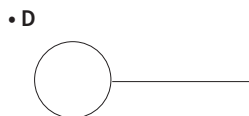
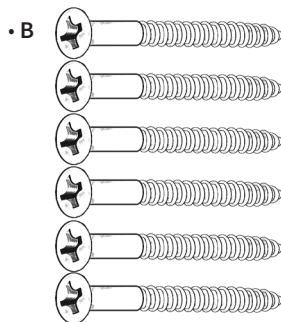

5. Product Features

*Transformer Tap & Bypass Switch
Access Point*

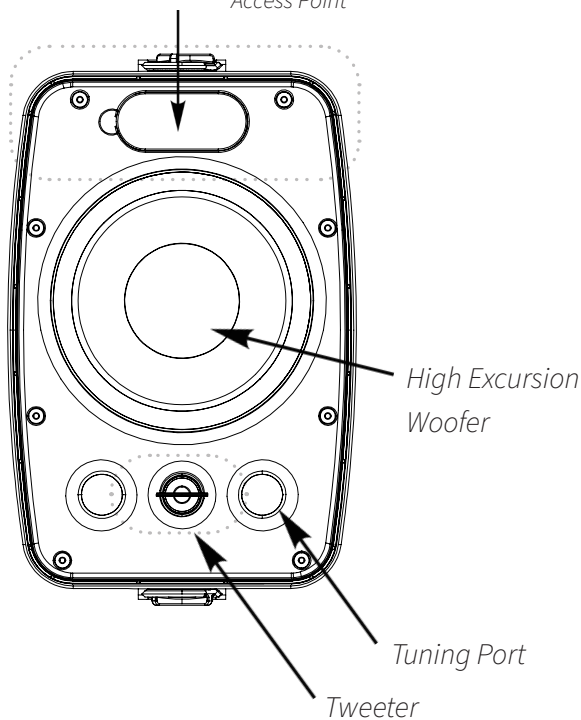

4-Pin Phoenix Connector

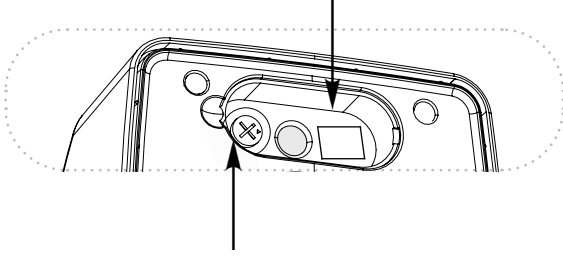

Transformer Tap & Bypass Switch

Transformer Tap & Bypass Switch

Enclosure

Access Point

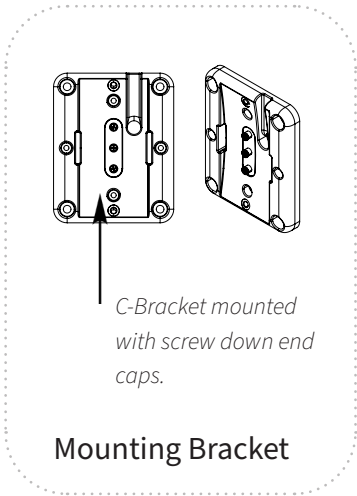

C-Bracket mounted with screw down end caps.

Mounting Bracket

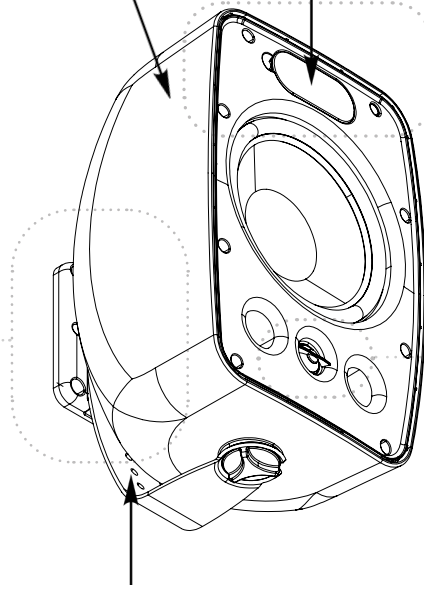

Weather Resistant POM Plastic C-Bracket with vertical angle adjustments

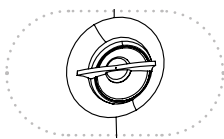

Tweeter

6. 70V/100V System

70/100-Volt systems are advantageous when the design calls for multiple speakers from the same amplifier and/or long-distance wire runs.

These Professional Collection 70V/100V Surface Mount Speakers feature multiple taps off the transformer, adjusted by a rotary switch on the front face of the speaker. The higher the wattage selected, the more output will be generated by the speaker.

Please note, 70V is common in the U.S. while 100V is the common voltage internationally, especially in Europe. A simple calculation is used to determine how many speakers can be driven on a single amplifier channel. First, for safety purposes, it is recommended to make the calculations based on 80% of the amplifiers rated power.

- For example, a 500-watt amplifier would safely deliver 400 watts of usable power ($500 \times 0.8 = 400$). Now it is simply a matter of dividing 400 by the tap setting of the speakers.
- For example, if the speakers are set at a 15W tap, the amplifier would be capable of driving 26 speakers per channel. At a 30W tap that would be 13 speakers. At a 60W tap that would be 6 speakers and so on.

As you can see, if you need coverage over a wide area and it requires numerous speakers, a 70V/100V system presents a tremendous advantage. However, it should be noted that the higher the wattage tap, the higher the fidelity and the greater SPL that can be delivered from each speaker. Therefore, it is best to determine the total number of speakers needed and set the taps as high as possible *WITHIN the amplifier's power output rating*.

As mentioned, the rotary switch used to adjust the tap setting is located on the front face of the speaker. For this reason, it is best to leave the grilles off until all of the tap settings have been properly adjusted.

The table below lists the power tap settings for each model. The same settings are reflected on the rotary switch on the front face of speaker (reference image below).

NOTE: There is an 8 Ω setting for both voltages that bypasses the transformer entirely. **Use caution to avoid this setting when connected to a 70V/100V amplifier as this can destroy the loudspeaker.**

The tap setting determines how much wattage each speaker will draw from the amplifier. When daisy-chaining multiple speakers: add the combined wattages of all tap settings, to determine the wattage draw on the amplifier. *The combined total wattage should NEVER exceed the wattage rating of the amplifier.*

MODEL	POSITION	1	2	3	4	5	6
PS80B PS80W	70V	80W	40W	20W	10W	OFF	-
	100V	-	80W	40W	20W		-
	8ohm	-	-	-	-		8 Ω
PS60B PS60W	70V	60W	30W	15W	7.5W	OFF	-
	100V	-	60W	30W	15W		-
	8ohm	-	-	-	-		8 Ω
PS50B PS50W	70V	30W	15W	7.5W	3.8W	OFF	-
	100V	-	30W	15W	7.5W		-
	8ohm	-	-	-	-		8 Ω

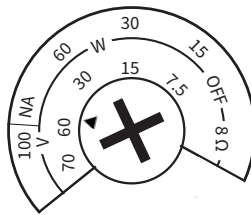

Tap Switch for
PS60B & PS60W

WARNING:

The 8 Ω position cannot be used with a 70/100V connection as it will damage or destroy the transformer.

Should you be uncomfortable designing or installing a 70/100V system, or should you have any questions please contact Origin Acoustics Technical Support.

NOTE: There is an 8Ω setting for both voltages that bypasses the transformer entirely. Use caution to avoid this setting when connected to a 70V/100V amplifier as this can destroy the loudspeaker.

The tap setting determines how much wattage each speaker will draw from the amplifier. When daisy-chaining multiple speakers: add the combined wattages of all tap settings, to determine the wattage draw on the amplifier. *The combined total wattage should NEVER exceed the wattage rating of the amplifier.*

7. Speaker Wire

The gauge of wire used can have an impact on the performance of your speakers. Generally, speaker wire is determined by the length of the run and wattage utilized. The longer your run is, the smaller the wire gauge must be.

On commercial 70 volt systems, 18 gauge, 2 conductor, stranded and jacketed without shield wire is commonly used.

Wire Length	Wire Gauge	System
0 -200' (0 - 60m)	18	70V / 100V
200-500' (60 -150m)	16	70V / 100V
Over 500' (150m)	14	70V / 100V

In residential systems, for relatively short runs (less than 50 feet) to 8 ohm speakers, 16 gauge wire will be usually suitable.

Wire Length	Wire Gauge	System
0 - 50' (0 - 15m)	16	8 Ohm
50 - 100' (15 - 45m)	14	8 Ohm
Over 100' (30m)	12	8 Ohm

8. Wire Routing

Plan how you will route the wire to the desired speaker location. There are several methods for routing the wire, and you may need to combine several of them.

Behind the Baseboard The wire can be routed behind the baseboard by cutting a groove out of the back of the baseboard, or by buying special baseboard designed for concealing wires.

Attic or Basement When available, you can route the wire through an attic or crawlspace.

Through Walls When running wires through a wall, be sure to avoid all obstacles such as AC wiring, pipes, and ducts.

Under the Carpet One option is to lift up the carpet and route "tape wire" under the carpet.

For New Construction If these speakers are being installed in a new home during construction, the installation process will be a bit different (although much simpler). For these situations, it is recommended you purchase a bracket. Instructions on how to install the speakers are provided with the bracket, or can be found on our website. Visit www.originacoustics.com for more information.

9. Wiring Diagram

Wiring Diagram for 70V/100V systems

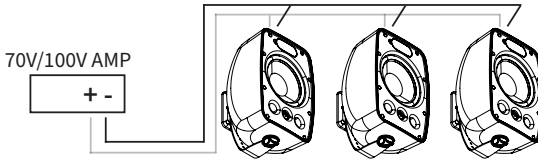

Wiring Diagram for 8 Ω system

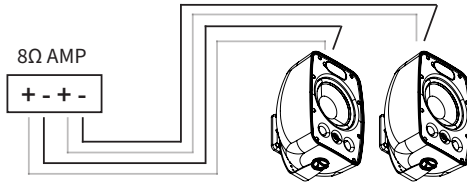

10. Speaker Placement

Speaker placement is determined by several factors like desired SPL, coverage requirements, variance in SPL by location, etc. When the objective is to fill a large area with very little variance (+/- 2dB), then a larger number of speakers is required. Typically, once the number of speakers has been determined, placing them equidistant from the listener and from each other will deliver the best result. However, due to other factors this may not be possible. The further the speaker is from the listener, the lower the SPL. As the speaker is placed closer to the wall, bass frequencies will be enhanced. This may or may not be the desired effect but certainly needs to be considered. The mounting system makes it easy to mount the speakers in a variety of positions and locations.

10a. Wall/Ceiling Mounting It is important that the bracket is securely mounted onto a structurally sound surface, capable of withstanding the weight of the product and any vibration created by the operation of the speaker. A screw size of #8 x 2" length or M4 x 50mm length is recommended. When mounting onto drywall or plasterboard, the bracket should be affixed to a joist or stud. When mounting onto brick or concrete, wall plugs or concrete anchors should be used. Can also be mounted directly onto a single or dual Gang Wall Junction Box.

10b. Pole Mounting To mount the speaker on a pole, U-bolt and nuts should be used to clamp around the pole and bolt through the holes on the back of the bracket. Spring washers or blue threadlocker are recommended to ensure the nuts do not work loose through the vibration of the speaker.

11. Installation

The best performance is obtained by placing the left and right speakers at ear level, 6 – 10 feet apart. The speakers should be facing the listeners. If you are mounting the speakers above or below ear level, pivot them up or down to direct the sound towards the listeners.

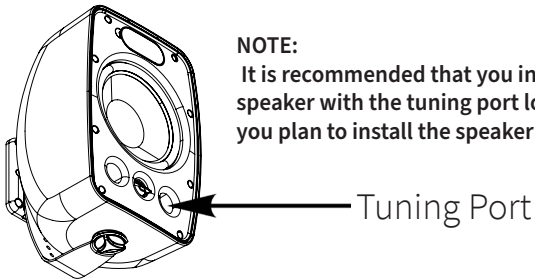

1. Run the speaker wires from the amplifier to the speaker location. Be sure to leave enough wire at the speaker location to feed through the hole in the speaker enclosure and wire to the terminal connector on the front.

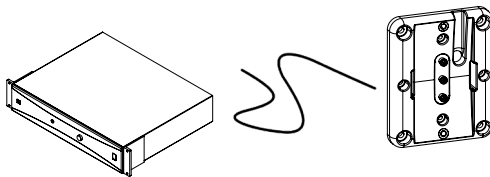

2. Attach the mount bracket to the mounting surface using 4 screws (not included), using studs or anchors, that are appropriate for the type of surface.

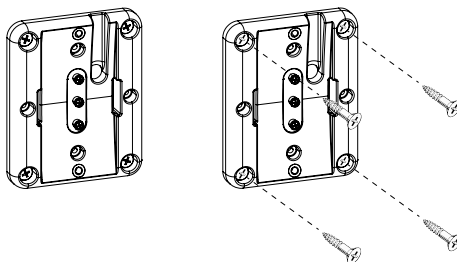

3. If the installation requires that the speakers be mounted on poles, you can attach the bracket to poles using U-bolt (not included).

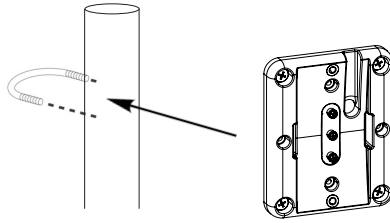

4. Pull the wire through the indicated wire feed hole on wall mount bracket. Then feed the speaker wire from the mount bracket into the wire entry hole on the back of the speaker, through and out of the opening on the speaker front panel. Make sure there is enough slack in the wire that will allow the speaker to pivot vertically on the C-bracket.

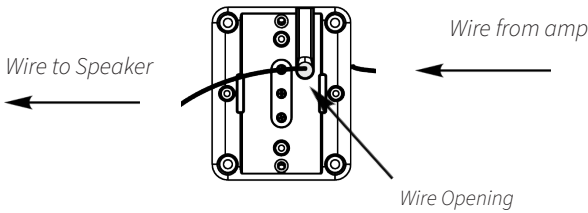

5. Attach the C-Bracket to the wall mount, after locating correct vertical angle. Screw down and attache securely to wall mount.

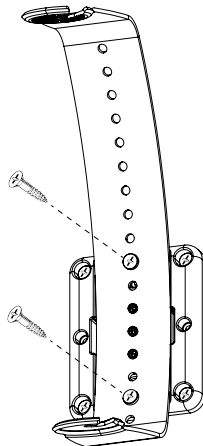

6. Attach the speaker to the C-Bracket, using the screw down caps and adjust correct horizontal angle.

A.

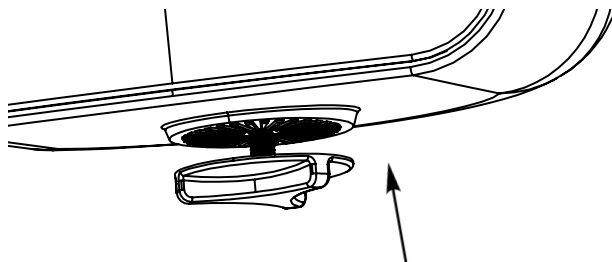

B.

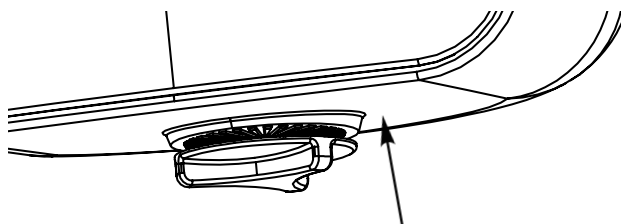

C.

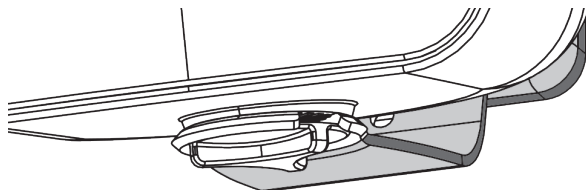

D.

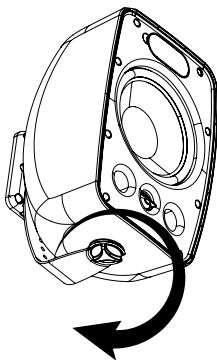

7. Connect the wire to the amplifier, and make sure the wire is correctly routed: eg: the left speaker output will be routed to the left speaker, right output to right speaker, etc. To connect the wire from the amplifier to the phoenix connector on the front speaker baffle:

7a. Strip approximately $\frac{3}{16}$ " (5mm) of the insulation off each wire, and to avoid stray strands, twist them at the end.

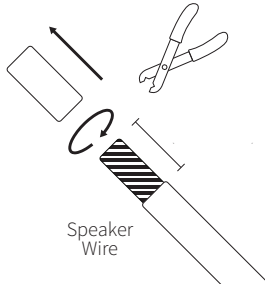

7b. Insert the wire into the correct square opening on the phoenix connector. Use a small flat head screwdriver to tighten the corresponding screw to secure the wire.

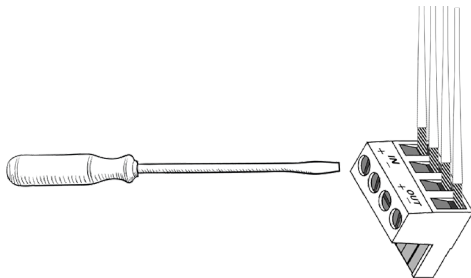
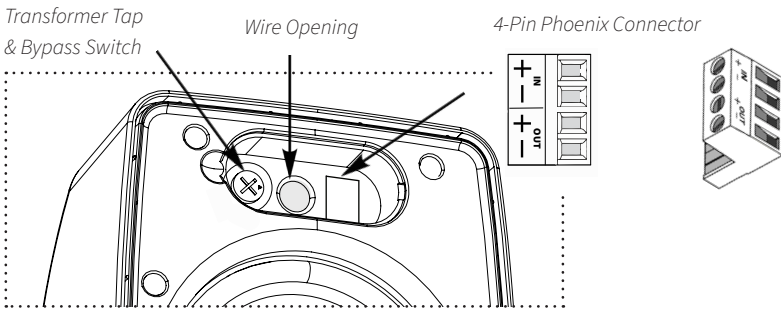

7c. When using multiple speakers you can connect the speakers either in parallel or in the loop through method as shown below.

Parallel Connection

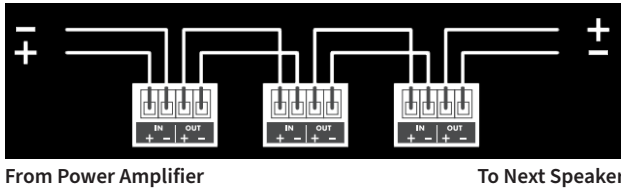

Loop Through Connection

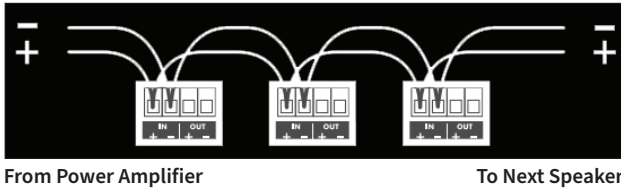

7d. Determine the proper wattage setting for each speaker in the installation and set each speaker's Transformer Tap selector on the front of the speaker accordingly. eg: You can set the tap to 70V Wattage or 8 ohm. Then fit the wiring terminal cover in the speaker front panel.

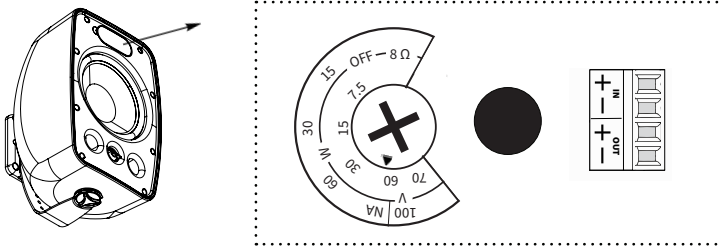

8. Add the grille adhesives around the grille gap, and then fit the grille onto the speaker.

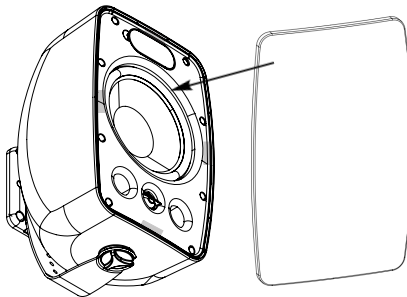

12. Pivoting The Speaker

The speaker features a Weather Resistant POM Plastic Bracket with vertical angle adjustments.

You can rotate the speaker between the two ends of the bracket (see A.), and also connect the speaker bracket on the vertical yoke mount (C Bracket) (see B.) at its desired vertical position. This allows the sound to be aimed towards the listeners as required.

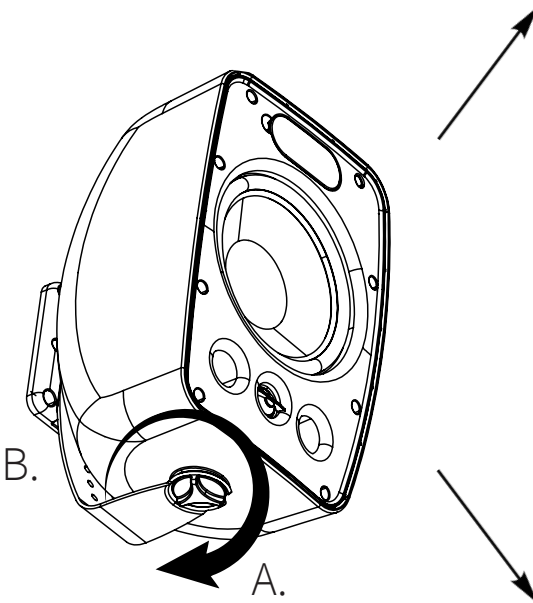

13. Safety Agency Compliance

Origin Acoustics Professional Collection Surface Mount Speaker models PS80B/ PS80W, PS60B/ PS60W, PS50B/ PS50W meet the following standards:

15A. UL 1480A: Standard for Speakers for Commercial and Professional Use

Scope:

1.1 These requirements cover speakers for indoor and/or outdoor use in dry, damp, wet, or underwater locations and are intended for one or more of the following:

- a) Commercial and professional audio systems providing non-emergency sound reinforcement and reproduction in accordance with the National Electrical Code, NFPA 70 (this includes equipment for institutional, industrial use);
- b) Non-fire emergency voice-warning systems in accordance with NFPA 70; examples of non-fire emergency-warning systems include, but are not limited to:
 - 1) Critical process monitoring (nuclear plant, oil refinery, hazardous chemical processing);
 - 2) Distress alert systems (help for handicapped, for life safety, for rape, for robbery);
 - 3) Crowd control in public places (sporting arena, theater, shopping mall, transportation center); and
 - 4) Non-fire emergency voice-systems covered by the Life Safety Code, NFPA 101.
- c) Underwater speakers in accordance with Article 680 of NFPA 70. An underwater speaker is not to be used in a fire alarm system or as an emergency (non-fire) voice-warning system.

1.2 These requirements do not cover the following:

- a) Speakers intended for use in hazardous locations as defined in the National Electrical Code, NFPA 70; this includes speakers tested with the requirements in the Standard for Explosion-Proof and Dust-Ignition-Proof Electrical Equipment For Use In Hazardous (Classified) Locations, UL 1203;
- b) Speakers intended for personal or private consumer use; this includes speakers for household/domestic use covered by the requirements in the Standard for Audio-Video Products and Accessories, UL 1492 and the Standard for Audio/Video and Musical Instrument Apparatus for Household, Commercial, and Similar General Use, UL 6500;
- c) Speakers which are intended for commercial or professional audio applications and which employ integral active electronics; these products are covered in the Standard for Commercial Audio Equipment, UL 813; the Standard for Professional Video and Audio Equipment, UL 1419; and the commercial audio amplifier applications covered in UL 6500;
- d) Speakers intended for security applications; these products are covered in the Standard for Local Burglar Alarm Units and Systems, UL 609; and the Standard for Household Burglar-Alarm System Units, UL 1023.

1.3 Speakers intended for use with fire alarm systems are covered by Standard for Speakers for Fire Alarm and Signaling Systems, Including Accessories, UL 1480. Speakers with integral amplifiers must comply with the requirements in UL 1480 and the Standard for Amplifiers for Fire Protective Signaling Systems, UL 1711.

1.4 Speakers intended for use with emergency and non-emergency systems and having integral amplifiers must comply with this standard in addition to the requirements in the Standard for General-Purpose Signaling Devices and Systems, UL 2017.

1.5 Speakers intended for use in air-handling spaces in accordance with Installation of Air Conditioning and Ventilating Systems, NFPA 90A, shall comply with the requirements in this standard and the requirements in the Standard for Fire Test for Heat and Visible Smoke Release for Discrete Products and Their Accessories Installed in Air-Handling Spaces, UL 2043.

15B. IEC 60529: IPX4 Rated

This standard applies to the classification of degrees of protection provided by enclosures for electrical equipment with a rated voltage not exceeding 72,5 kV.

Object: The object of this standard is to give:

a) Definitions for degrees of protection provided by enclosures of electrical equipment as regards:

- 1) protection of persons against access to hazardous parts inside the enclosure;
- 2) protection of the equipment inside the enclosure against ingress of solid foreign objects;
- 3) protection of the equipment inside the enclosure against harmful effects due to the ingress of water.

b) Designations for these degrees of protection.

c) Requirements for each designation.

d) Tests to be performed to verify that the enclosure meets the requirements of this standard.

It will remain the responsibility of individual technical committees to decide on the extent and manner in which, the classification is used in their standards and to define “enclosure” as it applies to their equipment. However, it is recommended that for a given classification the tests do not differ from those specified in this standard. If necessary, complementary requirements may be included in the relevant product standard. A guide for the details to be specified in relevant product standards is given in annex B.

For a particular type of equipment, a technical committee may specify different requirements provided that at least the same level of safety is ensured.

This standard deals only with enclosures that are in all other respects suitable for their intended use as specified in the relevant product standard and which from the point of view of materials and workmanship ensure that the claimed degrees of protection are maintained under the normal conditions of use.

This standard is also applicable to empty enclosures provided that the general test requirements are met and that the selected degree of protection is suitable for the type of equipment to be protected.

Measures to protect both the enclosure and the equipment inside the enclosure against external influences or conditions such as,

- mechanical impacts
- corrosion
- corrosive solvents (for example, cutting liquids)
- fungus
- vermin
- solar radiation
- icing
- moisture (for example, produced by condensation)
- explosive atmospheres,

and the protection against contact with hazardous moving parts external to the enclosure (such as fans), are matters for the relevant product standard to be protected.

Barriers external to the enclosure and not attached to it and obstacles which have been provided solely for the safety of personnel are not considered as a part of the enclosure and are not dealt with in this standard.

14. Troubleshooting

If you have a problem, try isolating it first. For example, if you're playing a DVD and there is no sound, try replacing the DVD with another audio source to see if you get sound. If it does work, then the problem is with the television, DVD player, or the cables connecting them. If it doesn't work, the problem will be with the amplifier, speakers, or those cables.

Problem	Possible Cause
No Sound	The volume may be turned down or muted. Check the volume settings on both the amplifier and the television/computer/CD player/etc.
No Sound	Make sure the proper source is selected on the amplifier or receiver.
No Sound	Check the cord connecting the amplifier with the source. The cord may be damaged or plugged into the wrong input or output.
No Sound	Check the wires connecting the amplifier with the speakers. Make sure they're connected properly and not damaged in any way.
Poor Sound Quality	If you hear something like static, or the sound is cutting in and out, check the audio cables. If the problem increases when a cable is being moved, then the cable is most likely faulty or not connected properly.
Poor Sound Quality	Today's audio systems may have several places to adjust the volume, for example your MP3 player may have a volume control, and your amplifier may also have one. Check to be certain that the volume isn't turned up past 80% on any device.
Poor Sound Quality	Try changing sources to be certain that the selection you've chosen is a good quality recording.

15. Technical Assistance

If you have any questions or concerns about installing or using this product, you can reach us through one of the following methods:

Phone: (844) 674-4461

Hours of operation: 8:00am - 5:00pm (Pacific Time), Mon - Fri

Email: sales@originacoustics.com

If you are having technical trouble, please include the model number and briefly explain what steps you took to resolve the problem in your email, or be prepared to answer these questions over the phone.

If you are considering returning the product, it's required that you contact Origin Acoustics prior to any return attempts. This way we can determine if the issue can be resolved without returning the product, or if needed we can provide instructions and support for the return process.

16. Limited 5-Year Warranty

Origin Acoustics warrants to the original retail purchaser only that this Origin Acoustics product will be free from defects in materials and workmanship, provided the speaker was purchased from an Origin Acoustics authorized dealer. If the product is determined to be defective, it will be repaired or replaced at Origin Acoustics' discretion. If the product must be replaced yet it is no longer manufactured, it will be replaced with a model of equal to or greater value that is the most similar to the original. If this is the case, installing the replacement model may require mounting modifications; Origin Acoustics will not be responsible for any such related costs.

Requirements & Warranty Coverage

This warranty may not be valid if the product was purchased through an unauthorized dealer. This warranty only applies to the individual that made the original purchase, and it cannot be applied to other purchases. The purchaser must be prepared to provide proof of purchase (receipt). This warranty will not be valid if the identifying number or serial number has been removed, defaced, or altered.

Not Covered by Warranty

- Accidental damage
- Damage caused by abuse or misuse
- Damage caused by attempted repairs/modifications by anyone other than Origin Acoustics or an authorized dealer
- Damage caused by improper installation
- Normal wear, maintenance, and environmental issues
- Damage caused by voltage inputs in excess of the rated maximum of the unit
- Damage inflicted during the return shipment

All warranties and warranty conditions are subject to change. Please refer to www.originacoustics.com for the latest information.

17. Return Process

Before making any return attempts, it is required that you first contact Origin Acoustics. Return product to Origin Acoustics or your dealer, either in person or by mail. It's preferable if the product is returned in the original packaging. If this is not possible, the customer is responsible for insuring the shipment for the full value of the product. This warranty is in lieu of all other expressed or implied warranties. Some states do not allow limitations on implied warranties, so this may not apply depending on the customer's location. (For more information, see Magnuson-Moss Warranty Act.)

NOTES



Rev. 3 • 10-26-22

6975 S Decatur Blvd, Las Vegas, NV 89118 • www.originacoustics.com • 844-674-4461

©2022 Origin Acoustics. All copyrighted, trademarked and patented elements mentioned herein are the sole property of Origin Acoustics.