

Adept Audio[®]

SOLSCAPE LS KIT 1 & 2

***Landscape Speaker System
Installation Manual***



1. INTRODUCTION

Thank you for buying Adept Audio Landscape Loudspeakers. These speakers were designed and tuned by the same engineers who invented multiple speaker satellite/subwoofer outdoor sound systems. They're built to install easily and quickly, and to sound fantastic day in and day out for years to come.

This manual provides all the necessary information for installation. If for any reason you experience problems or if you have installation questions, please call us at (888) 982-3378. Hours of operation are 8:00 AM to 5:00 PM (Pacific Time), Monday through Friday.

TABLE OF CONTENTS

| | |
|---|----|
| 1. Introduction..... | 2 |
| 2. Important Safety Instructions..... | 4 |
| 3. Warranty | 6 |
| 4. Tools Needed | 7 |
| 5. Speaker Cable Choice | 7 |
| 6. What's Included | 8 |
| 7. Specifications | 9 |
| 8a. L-300 Amplifier Features (Without Streamer) | 10 |
| 8b. L-300 Amplifier Features (With Streamer) | 12 |
| 9. System Planning & Installation..... | 14 |
| 10. L-300 Amplifier Calibration Steps | 20 |
| 11. Testing the System | 22 |
| 12. Troubleshooting | 23 |
| 13. Wiring Diagrams | 24 |
| 14. Technical Assistance | 28 |

2. IMPORTANT SAFETY INSTRUCTIONS

- Read these instructions.
- Keep these instructions.
- Heed all warnings.
- Follow all instructions.
- Do not use this apparatus near water.
- Clean only with dry cloth.
- Do not block any ventilation openings. Install in accordance with the manufacturer's instructions.
- Do not install near any heat sources such as radiators, heat registers, stoves, or other apparatus (including amplifiers) that produce heat.
- Do not defeat the safety purpose of the polarized or grounding type plug. A polarized plug has two blades with one wider than the other. A grounding type plug has two blades and a third grounding prong. The wide bladed or the third prong are provided for your safety. If the provided plug does not fit into your outlet, consult an electrician for replacement of the obsolete outlet.
- Protect the power cord from being walked on or pinched particularly at plugs, convenience receptacles, and the point where they exit from the apparatus.
- Only use attachments/accessories specified by the manufacturer.
- Use only with the cart, stand, tripod, bracket, or table specified by the manufacturer, or sold with the apparatus. When a cart is used, use caution when moving the cart/apparatus combination to avoid injury from tip-over.
- Unplug this apparatus during lightning storms or when unused for long periods of time.
- Refer all servicing to qualified service personnel. Servicing is required when the apparatus has been damaged in any way, such as power-supply cord or plug is damaged, liquid has been spilled or objects have fallen into the apparatus, the apparatus has been exposed to rain or moisture, does not operate normally, or has been dropped.

- To help maintain ambient temperature, **DO NOT mount in locations with direct sunlight.**

- To reduce the risk of electrical shock, do not open the equipment.

For safety reasons it is only allow to the opened by qualified service personnel.

- **WARNING:** To reduce the risk of fire or electric shock, do not expose this apparatus to rain or moisture. Additionally, the apparatus shall not be exposed to dripping or splashing and no objects filled with liquids shall be

placed on the apparatus.

- The mains plug is used as the disconnect device and shall remain readily operable.

- The product shall be used on open bench.

- No naked flame sources, such as lighted candles, should be placed on the apparatus.

- The apparatus should be connected to a mains socket outlet with a protective earthing connection.

- Ventilation should not be impeded by covering the ventilation openings with items, such as newspapers, table-cloths, curtains, etc.

- This apparatus is suitable for use in tropical climates.

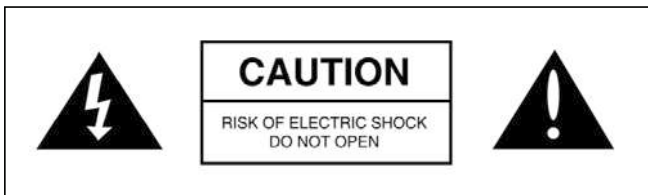

CAUTION: TO REDUCE THE RISK OF ELECTRIC SHOCK, DO NOT REMOVE COVER OR BACK. NO USER-SERVICEABLE PARTS INSIDE. REFER SERVICING TO AUTHORIZED SERVICE PERSONNEL.

WARNING: TO PREVENT FIRE OR SHOCK HAZARD, DO NOT EXPOSE THIS APPLIANCE TO RAIN OR MOISTURE. THE APPLIANCE SHALL NOT BE EXPOSED TO DRIPPING OR SPLASHING. NO OBJECTS FILLED WITH LIQUIDS SHALL BE PLACED ON THE APPLIANCE.

3. WARRANTY

Adept Audio warrants to the original retail purchaser only that this Adept Audio product will be free from defects in materials and workmanship, provided the speaker was purchased from an Adept Audio authorized dealer. If the product is determined to be defective, it will be repaired or replaced at Adept Audio's discretion. If the product must be replaced yet it is no longer manufactured, it will be replaced with a model of equal to or greater value that is the most similar to the original. If this is the case, installing the replacement model may require mounting modifications; Adept Audio will not be responsible for any such related costs.

3 YEAR LIMITED WARRANTY - L300 AMPLIFIER

LIMITED LIFETIME WARRANTY - SOLSAT4 & SOLSUB10

This warranty may not be valid if the product was purchased through an unauthorized dealer. This warranty only applies to the individual that made the original purchase, and it cannot be applied to other purchases. The purchaser must be prepared to provide proof of purchase (receipt). This warranty will not be valid if the identifying number or serial number has been removed, defaced, or altered.

Warranty Requirements & Warranty Coverage:

All warranties and warranty conditions are subject to change. Please refer to www.adept-audio.com for the latest information.

These conditions are not covered by warranty:

- Accidental damage
- Damage caused by abuse or misuse
- Damage caused by attempted repairs/modifications by anyone other than Adept Audio or an authorized dealer
- Damage caused by improper installation
- Normal wear, maintenance, and environmental issues
- Damage caused by voltage inputs in excess of the rated maximum of the unit
- Damage inflicted during the return shipment

4. TOOLS NEEDED

- Speaker Wire (Burial Grade)
- Wire Stripper
- Precision Screwdriver
- Shovel
- Trenching Shovel (Optional)
- Rubber Mallet (Optional)

5. SPEAKER CABLE CHOICE

Be sure to use burial-grade speaker cable for any cables that will be buried underground.

If the cables will be run through walls (such as running from the speaker system to an amplifier installed indoors), make sure your cables are CL3-rated for in-wall use.

To ensure the best performance from the speakers, use stranded speaker wire of the appropriate gauge for the length of the wire run.

| Wire Gauge | Wire Length |
|-------------------|--|
| 16 | 0 - 100 ft (0 - 30m) |
| 14 | 50 - 150 ft (15 - 45 m) |
| 12 | 100 - 250 ft (30 - 76m) MAX Length 250 ft (76m) |

6. WHAT'S INCLUDED

a. LSKIT 1

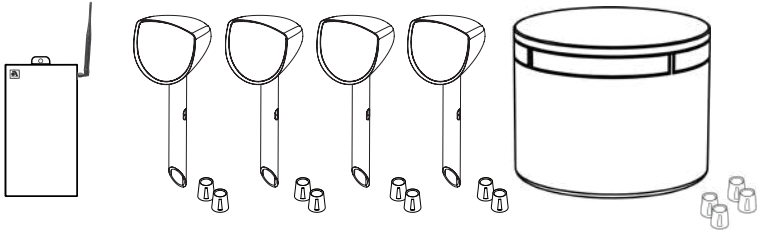

b. LSKIT 2

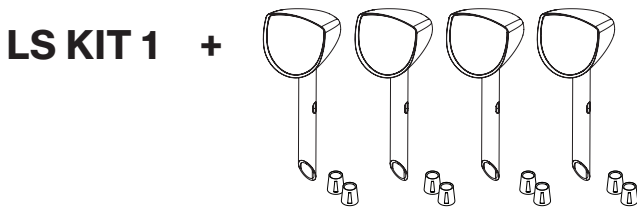

a. LSKIT 1

1 x L-300 Amplifier

1 x SOLSUB10 Burial/Hardscape Sub.

4 x SOLSAT4 Landscape Speakers with Integrated Stakes

12 x Wire Nuts

b. LSKIT 2

1 x LSKIT 1 (See LS Kit 1 above)

4 x SOLSAT4 Landscape Speakers with Integrated Stakes

8 x Wire Nuts

7. SPECIFICATIONS

SOLSAT4 Satellite Speakers:

- 4¼" Injection-Molded Polypropylene Woofers
- ¾" PEI Dome Tweeters
- Frequency Response: 120Hz - 20kHz
- Weather & UV Resistant ABS Enclosure
- Dimensions: 5.8" x 5.6" x 7.1" (147 x 142 x 180 mm)
- Ground Spike: 11" (249 mm)

SOLSUB10 Subwoofer:

- Installs In-Ground or Above Ground
- 10" Dual Voice-Coil Polypropylene Woofer
- Frequency Response: 35Hz – 150Hz [+/-10dB]
- Sealed Enclosure for Low Bass Extension
- 15¾" Dia x 12" H

System Impedance:

- 8Ω with 4 Sats & Subwoofer
- 4Ω with 8 Sats & Subwoofer

L-300 Digital 2-Channel Outdoor Amplifier:

- 2 Channels: 150W @ 8Ω / 250W @ 4Ω
- Expandable to Safely Run 8 SOLSAT4 satellites
- Surface Mounting
- Bluetooth Connectivity
- All Weather Finish IP66
- 7" W x 6.25" D x 12.75" H
- 120Hz LPF switch as subwoofer amp
- BTL Bridge mode switch
- Input sensitivity

8a. L-300 AMPLIFIER FEATURES (Without Streamer)

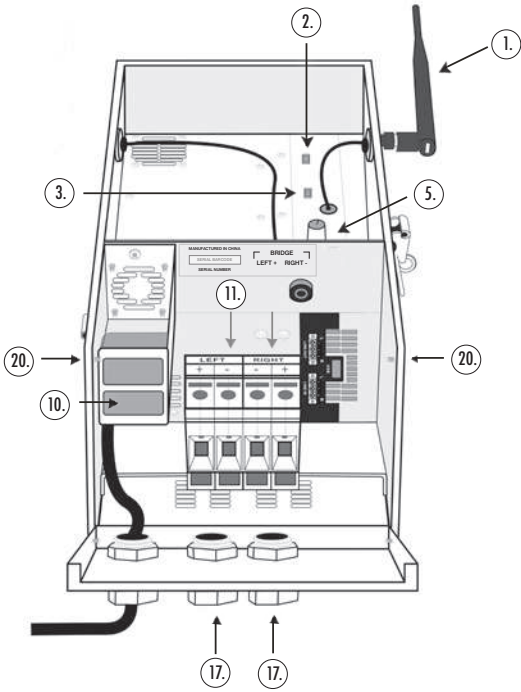

- 1. Bluetooth Antenna (1)
- 2. Bluetooth Switch
- 3. Bridge or Stereo Switch
- 4. Low Pass Filter (LPF) Switch
- 5. Gain Knob
- 6. Clipping/BT Indicator Lights
- 7. Speaker Output: Right
- 8. Speaker Output: Left
- 9. 120V AC Input
- 10. Fan
- 11. Bridge Speaker Output L+ & R-
- 12. Line OUT Phoenix Connection
- 13. Line IN Phoenix Connection
- 14. USB 5V Power Port
- 15. -
- 16. -
- 17. Speaker Wire Strain Reliefs (2)
- 18. Weather Resistant Enclosure
- 19. Mounting Tab
- 20. Bottom Panel Access Door:
(For easier access, loosen the 2 forward screws on each side & then pull panel downward)

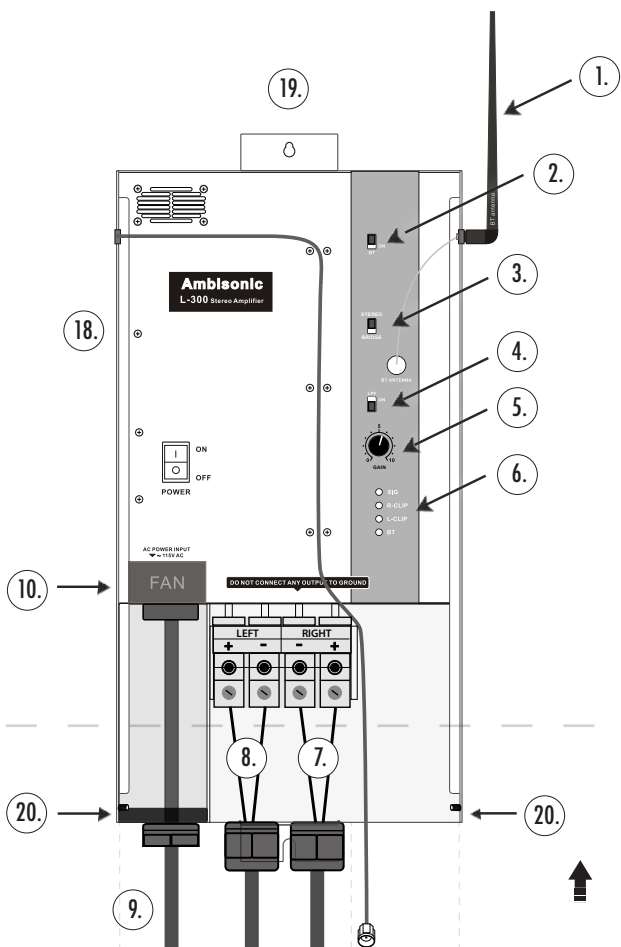

FRONT FACE VIEW

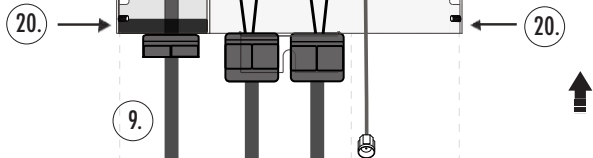

UNDERSIDE VIEW

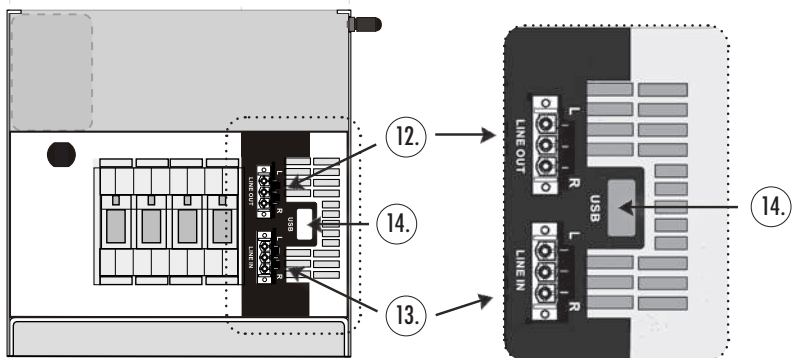

8b. L-300 AMPLIFIER FEATURES (With Streamer)

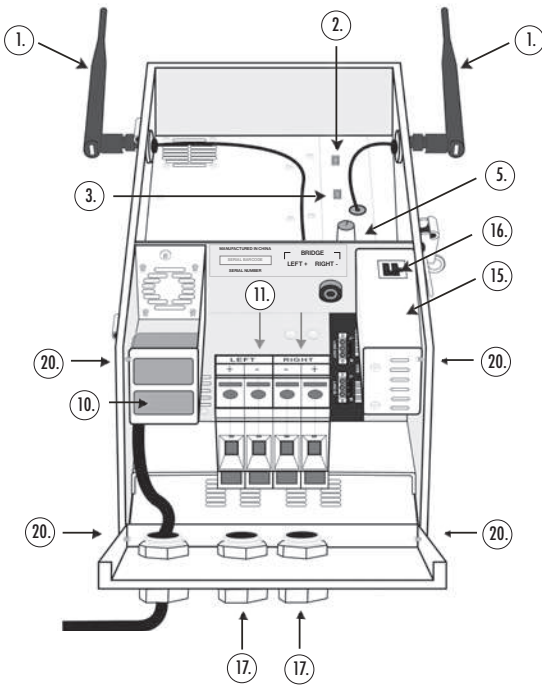

1. Bluetooth Antennas (2)
2. Bluetooth Switch
3. Bridge or Stereo Switch
4. Low Pass Filter (LPF) Switch
5. Gain Knob
6. Clipping/BT Indicator Lights
7. Speaker Output: Right
8. Speaker Output: Left
9. 120V AC Input
10. Fan
11. Bridge Speaker Output
L+ & R-
12. Line OUT Phoenix Connection
13. Line IN Phoenix Connection
14. USB 5V Power Port to Streamer
15. Streamer
16. RJ45 Internet Hardware
Connection
17. Speaker Wire Strain Reliefs (2)
18. Weather Resistant Enclosure
19. Mounting Tab
20. Bottom Panel Access Door:
(For easier access, loosen the
2 forward screws on each side &
then pull panel downward)

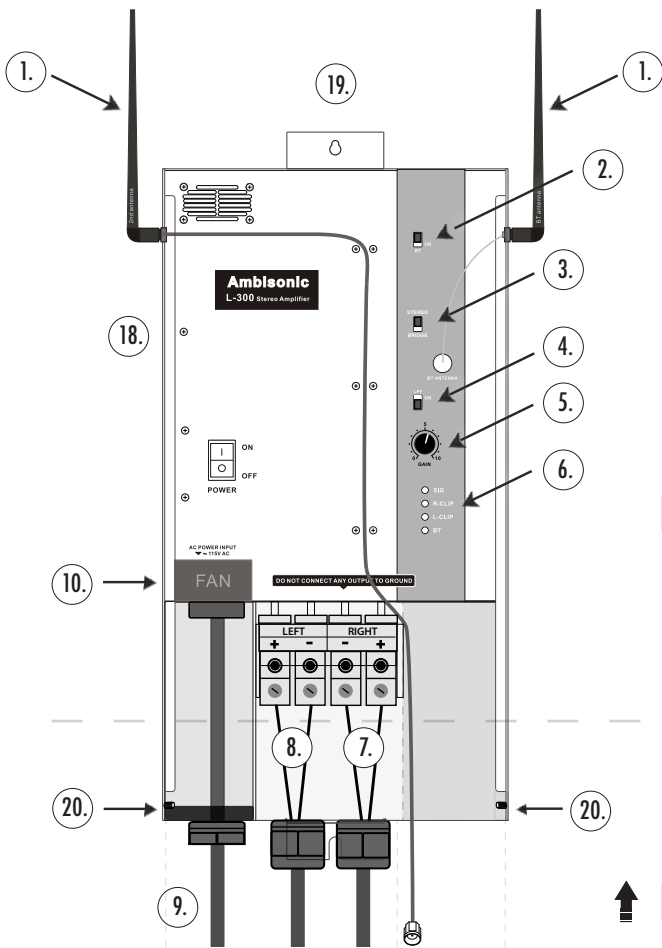

FRONT FACE VIEW

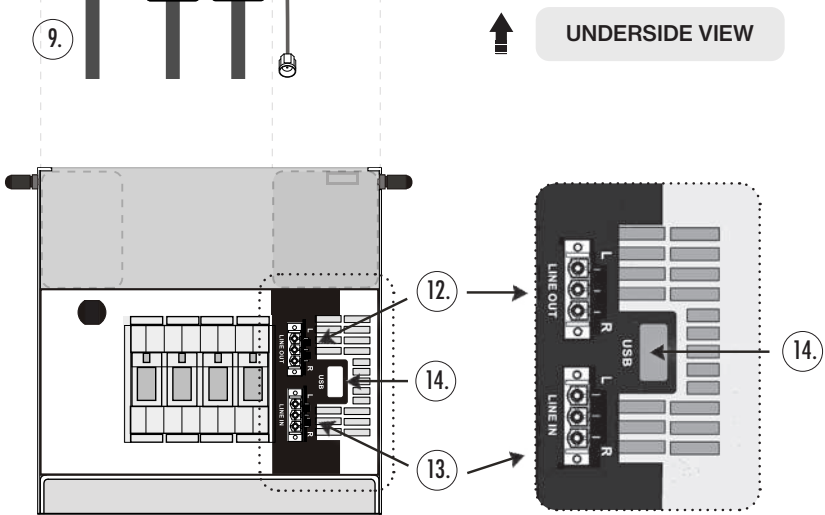

UNDERSIDE VIEW

9. SYSTEM PLANNING & INSTALLATION

The speakers and subwoofer should be strategically placed to evenly distribute sound throughout the outdoor area. Fully plan out the locations of the amp, all speakers, subwoofer and buried wires, before beginning the installation process.

The system is designed for the speakers to be evenly divided between two **PARALLEL** wire runs, with the subwoofer connected to both. The wires will be buried in single 5" trench.

9a. Positioning & Installing the Satellite Speakers

I. Speakers should be fairly evenly spaced, in a line, and aimed so they cover the listening area and so that sound is evenly dispersed around the outdoor space uniformly.

Δ Alternatively, you can create as many as four individual stereo pairs to focus sound onto certain areas of the outdoor space, such as patios or play areas. Alternate left-channel and right-channel satellite speakers when you install them.

Δ For best coverage, we recommend spacing the speakers 6 - 15 feet apart.

Δ Use a minimum of 14 AWG wire.

Δ Do not place speakers in direct line with sprinkler spray.

II. Push the mounting spikes for the satellite speakers to vertically plumb into the ground.

Δ Be sure to have the wire hole on the side of the stake facing away from the listening area.

Δ If the ground too firm to push the spike in all the way, remove the speaker from the spike and tap the spike in gently with a rubber mallet.

Δ Be careful not to use too much force on the spikes, because they can break.

III. Feed the speaker wire through the top hole of the ground stake and out the wire hole on the side of the stake.

△ The speaker can now be screwed onto the stake clockwise until tight.

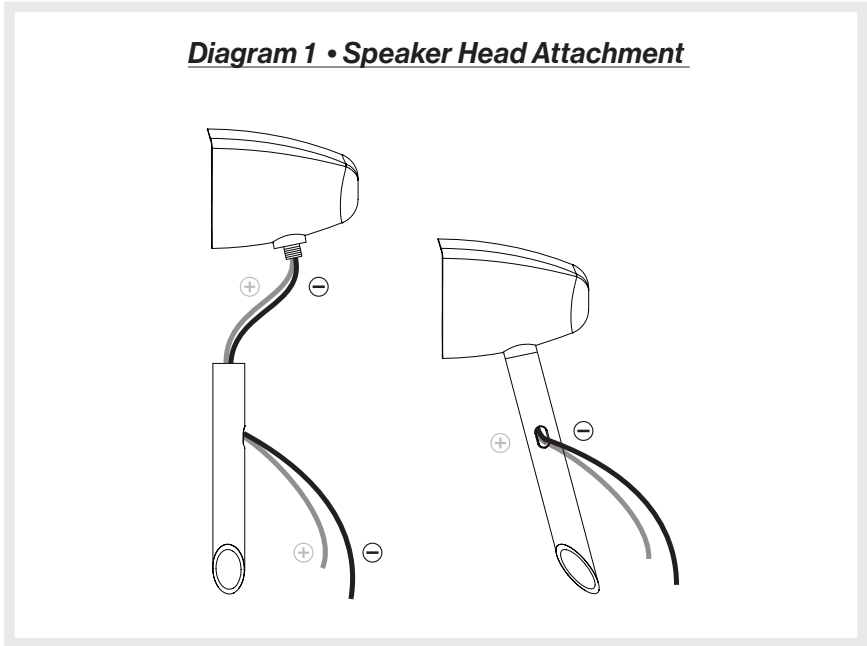

9b. Positioning & Installing the Subwoofer

I. The SOLSUB10 dimensions are 15³/₄" diameter x 12" high.

△ Select a location for the subwoofer somewhat near the middle of the speaker arrangement. It should be placed as close to the middle of the speaker system as practical, ideally with half the satellite speakers on one side and half on the other.

II. For more bass, install the subwoofer near a wall or other solid surface.

△ Subwoofer should be positioned away from standing water.

△ You can place the subwoofer directly on the ground, or bury most of it.

III. If the SUB10 will be in-ground, make a hole 16" diameter x 7" deep and insert the subwoofer.

Δ Bury **NO MORE** than 7" deep.

Δ Be sure the “grilles” are high enough as to not get submerged.

Place subwoofer, as level as possible, not tilted, in the center of hole & use loose dirt to level the subwoofer, ensuring the subwoofer is not in direct contact with any large rocks or large empty holes.

Fill remaining space around subwoofer with loose dirt. Ensure that all vents are exposed and allow a visible space of about 5" from the ground level to the top of the subwoofer.

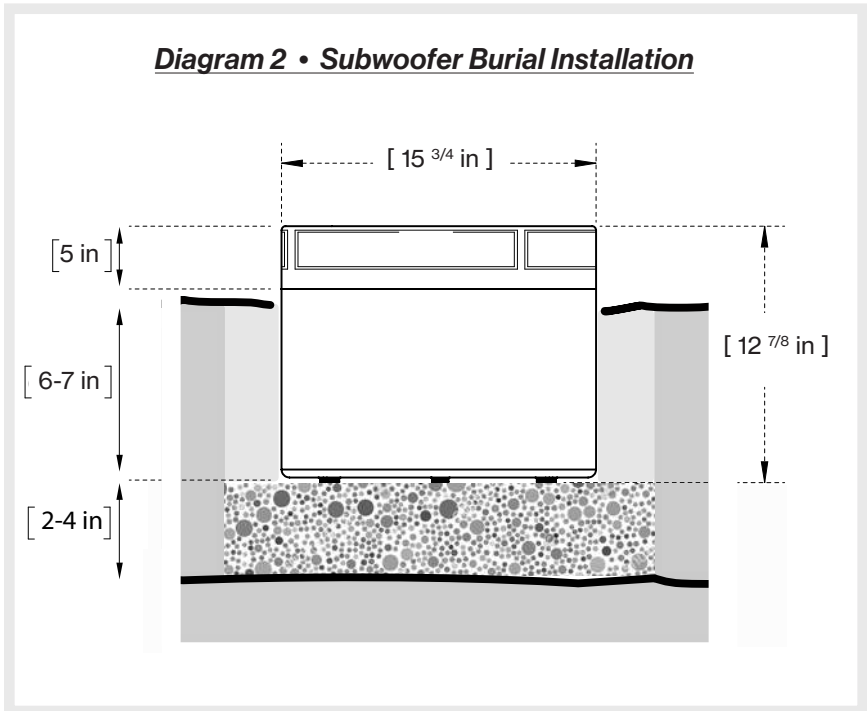

9c. Positioning & Installing the Amplifier

Δ Locate a shaded area for the amplifier to be installed out of direct sunlight.

Δ Use a minimum of 14 AWG wire for sending a strong signal.

9d. Running Wires from the Amplifier to the Speaker & Subwoofer

I. Dig a 5" trench where you plan on laying out the wire. Run the left and right speaker cables from the amplifier to the subwoofer location. The amplifier should be turned off & with the volume turned down. The subwoofer should have four input connections:

Δ **WHITE / Positive | GREEN / Negative (Left Channel)**

Δ **RED / Positive | BLACK / Negative (Right Channel)**

Diagram 3 • Wiring from Amp to Subwoofer

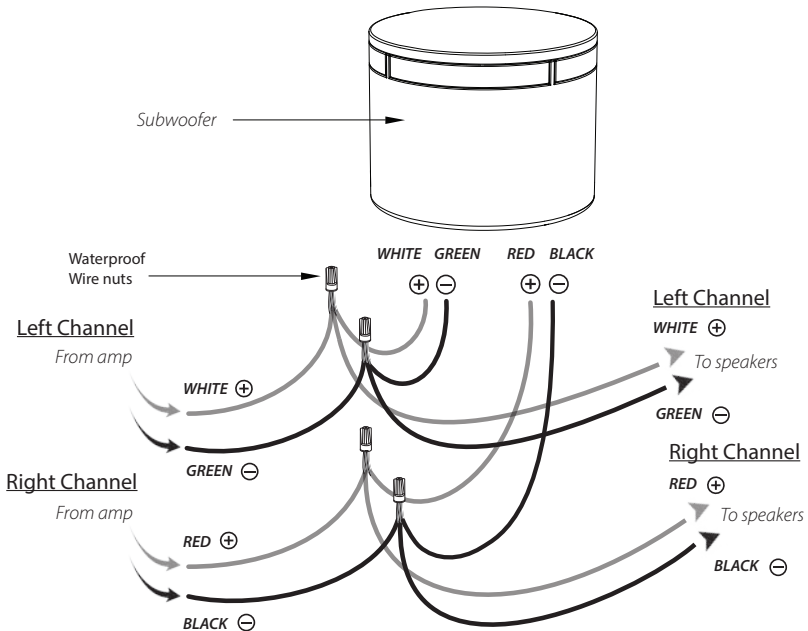

Making sure to use the supplied waterproof wire nuts, connect both left and right channels to the subwoofer, making sure positive is connected to positive and negative is connected to negative. Continue down the line and connect the rest of the speakers.

II. From the subwoofer location, extend the left speaker cable to the left satellite speakers and the right speaker cable to the right satellite speakers using a parallel connection. Strip ½" of the jacket off the ends of all cables.

Left Channel: WHITE = Positive | GREEN = Negative

III. Connect the **LEFT** positive conductor from the amp, to the **LEFT** input on the subwoofer.

Δ Extend from the subwoofer to the first **LEFT** satellite speaker. Connect the **LEFT +** to the **WHITE +** wire and the **LEFT -** to the **GREEN -** wire on the 1st **LEFT** satellite speaker. *(See Diagram 6 a/b, Page 24)*

Δ Extend to the 2nd **LEFT** satellite speaker in the same manner. Repeat this process if using additional satellite speakers on the **LEFT** channel (**MAX** of 4 satellites on each channel). Connect speakers and subwoofer using only the supplied waterproof wire nuts.

Right Channel: RED = Positive | BLACK = Negative

IV. Connect the **RIGHT** positive conductor from the amp, to the **RIGHT** input on the subwoofer.

Δ Extend from the subwoofer to the first **RIGHT** satellite speaker and connect the **RIGHT +** to the **RED +** wire and the **RIGHT -** to the **BLACK-** wire on the 1st **RIGHT** satellite speaker. *(See Diagram 6 a/b, Page 24)*

Δ Extend to the 2nd **RIGHT** satellite speaker in the same manner. Repeat this process if using additional satellite speakers on the **RIGHT** channel

Δ (**MAXIMUM** of 4 satellites on each channel).

Δ Connect speakers and subwoofer, making absolutely sure you always connect positive to positive and negative to negative. And be sure to connect right and left channels correctly. (See *Diagram 3, Page 17*)

If you wire Positive (+) to Negative (-), the system will not perform as it should. Make all speaker connections and test the system **BEFORE** burying the wire.

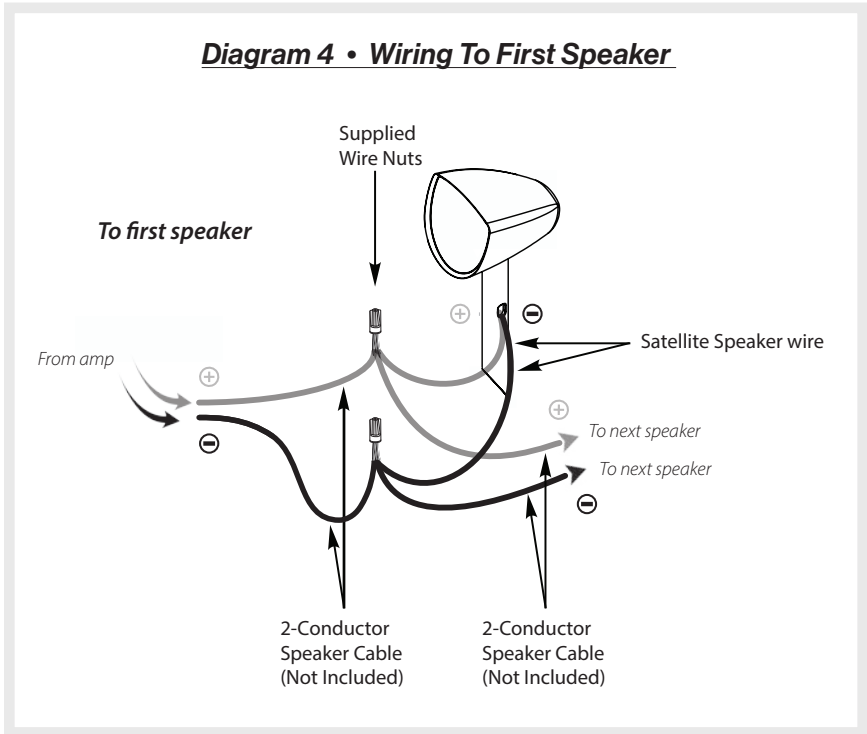

(Diagrams 8 a/b, pages 26 & 27, show Left Side/Right Side wiring options and Left-Right/Left-Right wiring options)

Once system is wired up, follow these Calibration Steps:

10. L-300 Amplifier Calibration Steps

• After following these calibration steps for the GAIN KNOB, then ONLY use the source device to control volume.

△ **DO NOT ENGAGE BRIDGE MODE FOR ANY OF THE KITS**

△ **ONLY ENGAGE LPF ON THE SUBWOOFER AMP IN KIT 4**

Step 1 • Use the knob labeled “Volume Dial” as the GAIN KNOB. Turn GAIN KNOB, anticlockwise, all the way down to the left, towards the number 1.

Step 2 • Connect your source device. Turn the volume all the way up. Play some audio.

Step 3 • Slowly turn the GAIN knob on the L300 amp clockwise, to the right, toward the number 10.

As soon as you see the red lights start to show: dial the knob back to the left slightly, so the clipping lights do not show. Now this is the ideal position & should be left as is, so volume can be controlled from the source device.

Step 4 • After following these calibration steps, ONLY the source device should be used to control volume during future use.

Note • There is **NO** need to engage LPF.

LPF should only be engaged on the Subwoofer Amp if used with SOLSCAPE Kit 4.

Once you're confident that the system is working correctly, go ahead and bury the wires. After the wires are buried, check the system once again to make sure all the speakers and the subwoofer are connected.

Diagram 5 • L-300 Amplifier Calibration

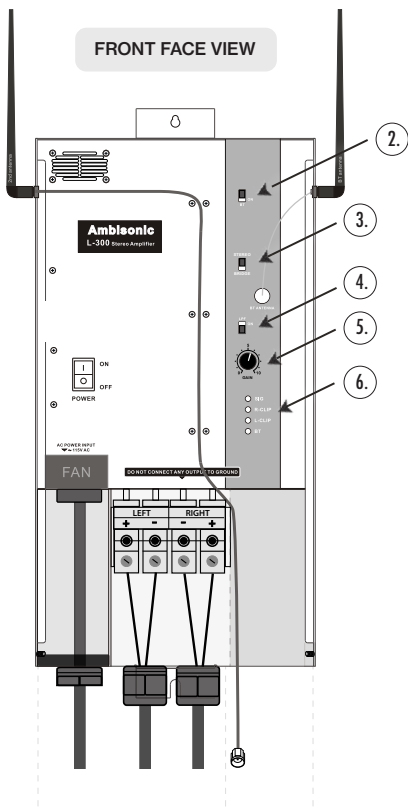

- 2. Bluetooth Switch
- 3. Bridge or Stereo Switch
- 4. Low Pass Filter (LPF) Switch
- 5. Gain Knob
- 6. Clipping/BT Indicator Lights

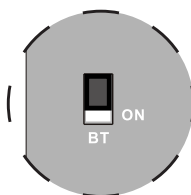

- 2. BLUETOOTH SWITCH

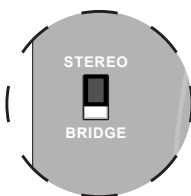

- 3. BRIDGE SWITCH
[KEEP OFF]

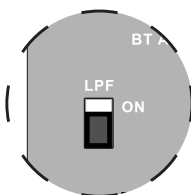

- 4. LPF SWITCH
[KEEP OFF]

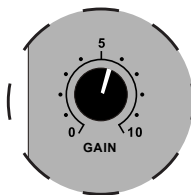

- 5. GAIN KNOB

11. TESTING THE SYSTEM

Get the system playing, then go up close to each of the satellite speakers and the subwoofer to make sure all of them are working.

If any one speaker is not working, check the connection for that speaker. If multiple speakers are not working, start by checking the connection for the disconnected speaker that's closest to the subwoofer, then check the other connections down the line until you get all the satellites working.

Play a tune with vocals.

Stand equidistant from the first left/right pair of satellite speakers. The vocals should mostly seem to coming from a point between the left and right speakers. If the vocals sound spacey, like they're coming from all around, check the positive and negative polarity connections for that pair of speakers. Repeat with all the other left/right pairs.

Once the system passes setup and all is working, you can now bury the wire.

12. TROUBLESHOOTING

No sound from all speakers:

Make sure the amplifier and source device (music streamer, multi-room controller, etc.) are turned on, music is playing, and the volume is turned up. Check the connections between the source device and the L-300 to make sure they are firmly connected and that the cables are in good condition. Check the connections on the speaker cables between the L-300 and the subwoofer to make sure they are securely connected.

No sound from one speaker:

Dig down to find the cable connection to that speaker and check the connection to make sure it's secure. If the connection seems good, try connecting a spare speaker to see if it works. If the spare speaker works but the Landscape speaker doesn't, contact Adept Audio.

No sound from all the right-channel or all the left-channel speakers:

Check to make sure the source device is connected to the input of the L-300. Check the connections on the speaker cable for that channel going from the L300 to the subwoofer, and the connection going from the L-300 to the first satellite speaker for that channel.

Bass is weak:

Check the polarity of the speaker cables going from the L-300 to the subwoofer, and make sure positive is connected to positive and negative to negative on both ends of both cables.

13. WIRING DIAGRAMS *Diagram 6a • LS KIT 1*

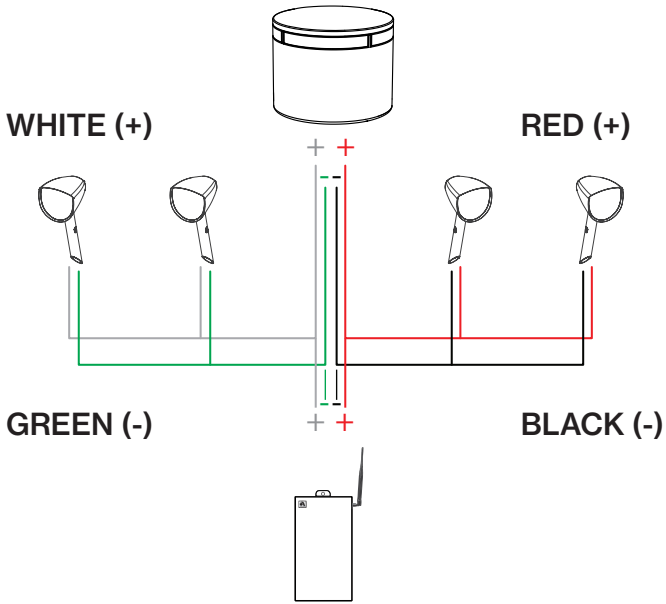

Diagram 6b • LS KIT 2

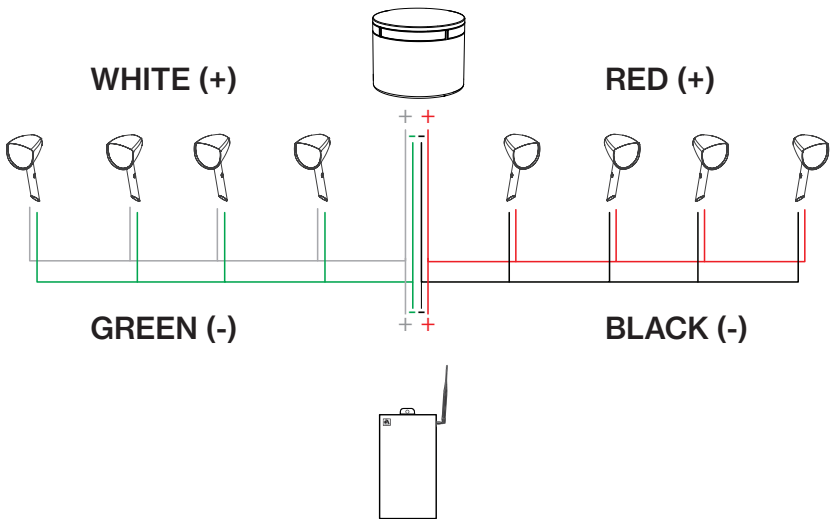

Diagram 7a • LS KIT 1 (Covers Approx. 1,500 SQFT)

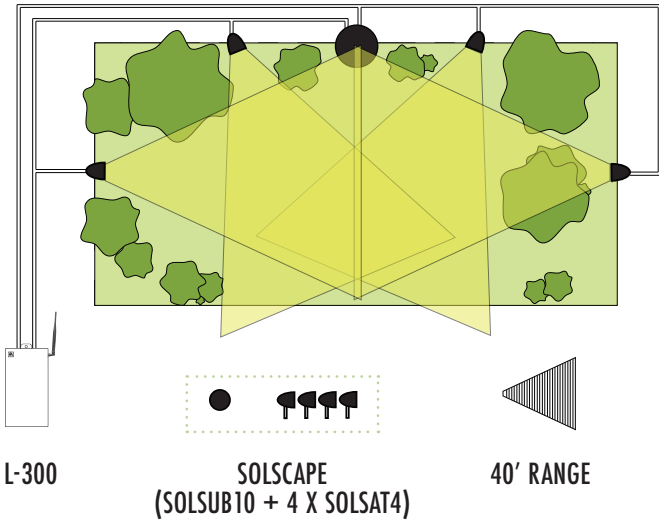

Diagram 7b • LS KIT 2 (Covers Approx. 2,500 SQFT)

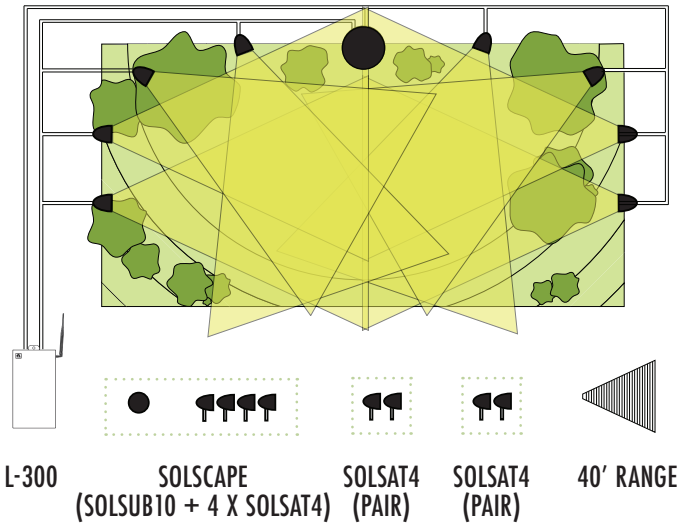

Diagram 8a • Left Side Right Side Wiring

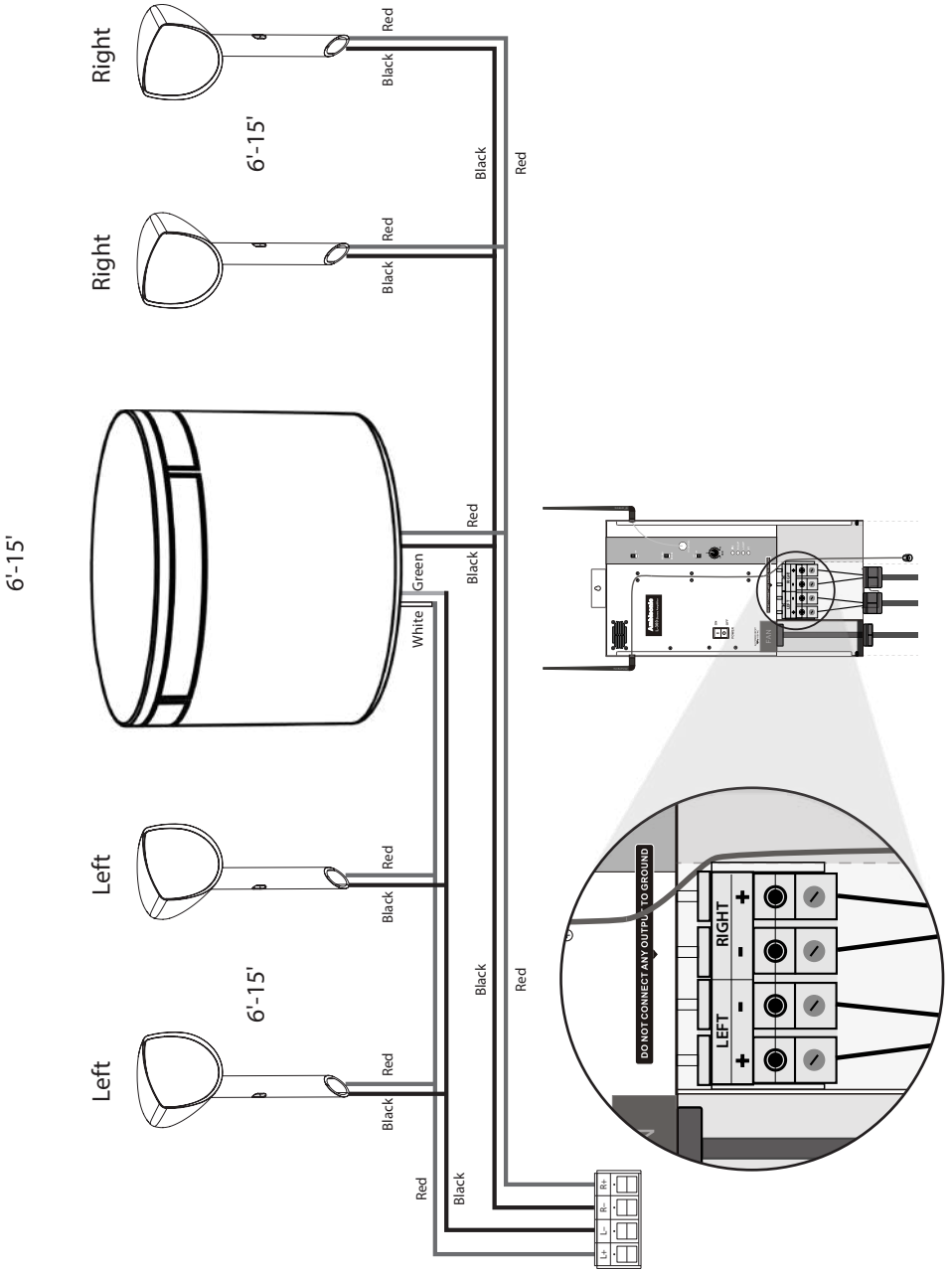
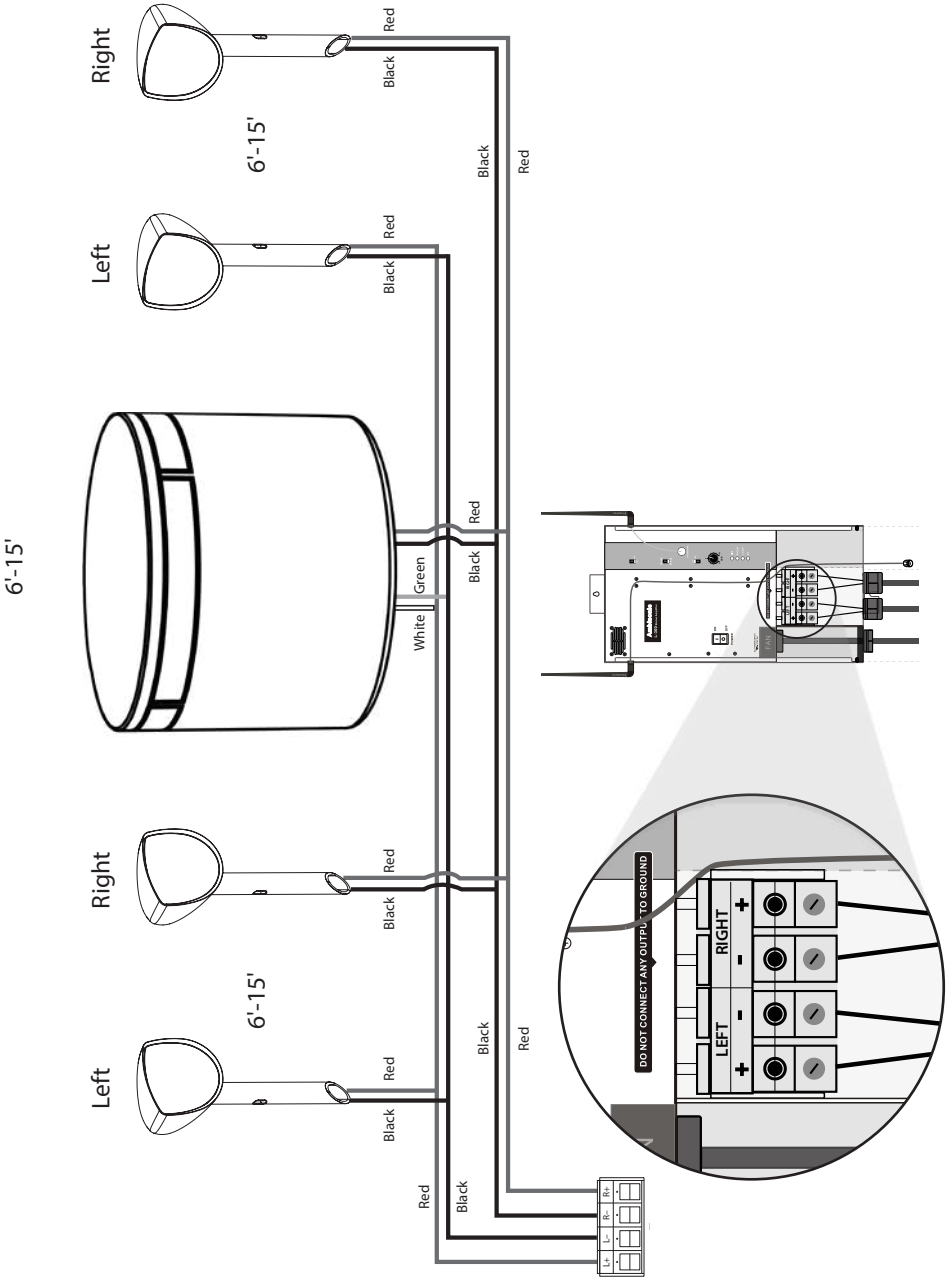

Diagram 8b • Left Right Left Right Wiring



If you have any questions or concerns about installing or using this product, you can reach us through one of the following methods:

Phone: (888) 982-3378

Hours of operation: 8:00am - 5:00pm (Pacific Time), Mon - Fri

Email: techsupport@adept-audio.com

If you are having technical trouble, please include the model number and briefly explain what steps you took to resolve the problem in your email, or be prepared to answer these questions over the phone. If you are considering returning the product, it's required that you contact Adept Audio prior to any return attempts. This way we can determine if the issue can be resolved without returning the product, or if needed we can provide instructions and support for the return process.

Adept Audio®

adept-audio.com

©2023 Adept Audio. All copyrighted, trademarked and patented elements mentioned herein are the sole property of Adept Audio

04-13-23